

NEPTUNE SERIES



BOAT LIFT EXPERT

- ▶ Cummins 6.7L Diesel Engine (Tier 4 Final)
- ▶ Dana TE-14 Series Transmission
- ▶ Operator Presence Sensing System (OPSS)
- ▶ 15,000 - 55,000 lb. Capacity
- ▶ Swing-Style Fork Carriage
- ▶ 7" TFT Touchscreen Display



HOIST NEPTUNE SERIES ADVANTAGES

▶ **CUMMINS 6.7L, 6-CYLINDER DIESEL ENGINE**

powers the heaviest applications while meeting tough emission standards.

▶ **AXLETECH HEAVY-DUTY FRONT AXLE** with

wet brakes provides maximum durability.

▶ **EXCELLENT VISIBILITY** from the operator's

position in all directions.





▶ **SPECIALLY DESIGNED MAST** with negative lift to pull boats out at dock level.

▶ **SWING-STYLE FORK CARRIAGE** features dependent and independent fork control for precise load handling.

▶ **GALVANIZED MARINA FORKS** feature a rubber fork covering to prevent marring of hulls.

▶ **ELECTRONIC JOYSTICK CONTROLS** feature highly intuitive and ergonomically designed to increase comfort and productivity.

▶ **AIR-RIDE SEAT** provides superior operator comfort throughout the entire work shift.

▶ **DANA TE-14 SERIES TRANSMISSION** with 3 forward and 3 reverse speeds.

▶ **SMART SCREEN TECHNOLOGY** includes customizable performance, advanced diagnostics, and pertinent forklift information right at your fingertips.

TECHNOLOGY TODAY FOR TOMORROW'S DEMANDS

SMOOTH CONTROL: ONBOARD OR OFF

We thought outside the box so that you could work outside of your forklift. With our optional wireless remote control feature, situations requiring precise control can be handled safely and efficiently. Forklift functions such as drive, lift/lower, tilt, and fork manipulation can be controlled directly through the remote, allowing for expert control from the appropriate vantage point.

Designed with ergonomics in mind, these controls include a waist strap to reduce operator fatigue allowing for optimal focus on the task at hand. Rechargeable batteries for the remote can also be charged directly on the forklift, helping to ensure longer run-time and less downtime for charging.

AMENITIES COME STANDARD

Advanced ergonomics and intuitive design keep you comfortable and productive throughout your entire shift. Your voyage begins with a premium air-ride seat, a two-stage wide-view mast, and a low-profile counterweight for superior visibility. You'll also be equipped with electronic joystick controls engineered with optimal placement and ease of use for smooth operation. These are just a few of the creature comforts that come standard when you embark with the Neptune Series.

BUILT MARINA TOUGH

The Hoist brand is synonymous with strength and durability, and the Neptune Series is no exception. A 100% welded steel chassis with steel cross supports is built to take on the toughest challenges at your boatyard or marina. And our AxleTech planetary drive axle with force-cooled wet disc brakes is designed for maximum durability in high-capacity applications. Even the paint is tough. A three-step paint process provides maximum corrosion protection perfectly suited for wet marina applications.

PERFORMANCE THAT KEEPS UP WITH THE CHANGING TIDES

We know you're handling precious cargo. That's why Hoist's Neptune Series forklifts come standard with what you'll need to ensure superior performance and reliability. A high-performance 6.7L Cummins diesel engine delivers exceptional power and efficiency while also meeting today's stringent emissions regulations. The Dana TE-14 Series Transmission is designed to provide higher input capability and reduced maintenance. This powerful combination ensures you're set for maximum heavy-duty productivity with minimal downtime.

7" TFT TOUCHSCREEN DISPLAY

Making a forklift that can work for you is what Hoist does every day. Building a forklift that works with you is another story – your story. Hoist's Smart Screen Technology (SST), multi-function display puts the latest technological advancements right at your fingertips to help you get your job done.

With the SST display's built-in estimated rack height calculator, you'll have quick access to your forklift's lifting capabilities based on both boat size and drive style. Need a customized pre-operational checklist? Upon request, the SST display can come pre-programmed to fit your specific needs. User-access control is also available through a pin code entry system which limits use of the forklift to designated operators, reducing the likelihood of use by unauthorized personnel.

Hydraulic schematics, wiring diagrams, and fuse/relay diagnostics are available directly through the SST display, making diagnosing technical issues easier than ever before. That's important because every minute of uptime translates to productivity and revenue.



Smart Screen Technology - Neptune Series



NEPTUNE SERIES

CAPACITY
15000 – 55000 LBS.

WHEELBASE
94 – 170 IN.

LOAD CENTER
96 IN.

INDUSTRIES



Marina



Government /
Municipality



Boat
Manufacturing

STANDARD FEATURES

SUPPORT

- Electrical horn
- Asbestos free components
- Spring-applied/hydraulic release parking brake
- Operator Restraint System seat
- Operator Presence Sensing System (OPSS)

PERFORMANCE

- Cummins Tier 4 Final 6.7L Diesel Engine
- Dana TE-14 Series Transmission
 - 3FWD/3REV gears
 - Dedicated cooling system
 - Electronic shift control
- Declutch control pedal
- Swing-style fork carriage (independent and dependent)
- Interactive CAN-bus vehicle management system
- Electronic engine diagnostics with fault code history
- Bolted open core radiator with high-capacity cooling system
- External sump tank provides additional cooling
- 100 amp alternator with built-in regulator
- 7" TFT touchscreen display
 - Fuel gauge
 - Hour meter
- Tachometer
- Water temperature gauge
- Estimated rack height calculator
- Engine oil pressure
- Parking brake indicator
- Estimated load weight indicator
- Service and operator manuals
- Pre-operation checklist (upon request)¹
- Fuse/relay diagnostics

DURABILITY

- Axletech heavy-duty planetary drive axle rated for durability in high-capacity applications
- Force-cooled wet disc brakes
- Galvanized forks and carriage for ultimate corrosion protection
- Two-part rust-inhibiting polyurethane base coat and two-part polyurethane top coat for corrosion protection
- Algae filtration system
- Carriage wear blocks
- Heavy-duty, isolated drive line mounts
- Two easily accessible 12V industrial batteries
- Anti-restart ignition switch
- Welded steel chassis with heavy-duty cross supports
- Dual action bolt-on cylinder protected by heavy steel support beams
- High-impact composite trunions
- Sealed, tapered roller bearings
- Forged steer knuckle
- Oversized steer linkage
- Stainless steel hydraulic bulkhead fittings (carriage and mast)
- Stainless steel, corrosion resistant rods, ends, and pins on swing cylinders
- Lubricated mast rollers
- Long life, corrosion resistant wear pads
- Rubber fork covering system

ERGONOMICS

- Electronic joystick controls
- Air-ride seat
- Low-profile counterweight
- Tilt steering column
- Left hand shift lever on steering column
- Two-stage, wide-view mast
- Low-height, non-skid steps with operator handrails
- Splash guard in front of operator platform
- Rear collision sensor w/ visual and audible warning
- Overhead mounted tilt cylinders
- Lift circuit accumulator
- LED headlights
- Rear LED work lights
- Rear LED combo lights

SERVICEABILITY

- Lubricated, sealed, and greasable main rollers on each side of the mast
- O-ring face seal fittings on entire system to prevent oil leaks
- Tilt-lock valve with counterbalance to prevent mast drift
- Large, bolt-on fuel and hydraulic tanks
- Easy-access filters
- Low chassis side plates provide easy drive train access
- Hydraulic multi-gauge
- Integrated lift points
- Wet disc brakes serviceable through wheel ends
- Easy-access lubrication points

¹ Consult your local, authorized Hoist dealer for customization options and pricing.

Please contact your local, authorized Hoist dealer for a complete list of available options.

CAPACITY LIST

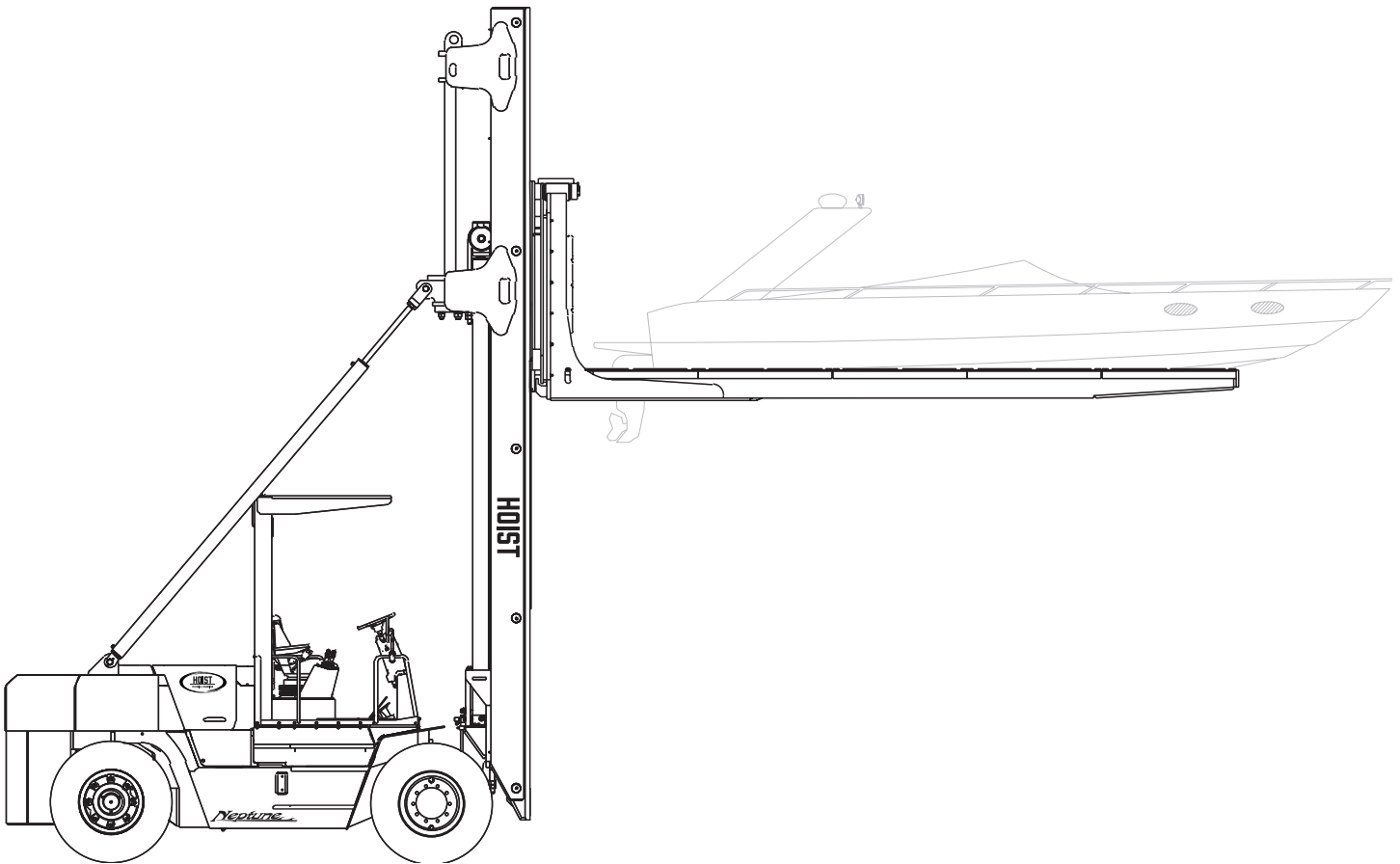

MODEL	CAPACITY (LBS.) @ 96 IN.	WHEELBASE (IN.)	CAPACITY (LBS.) @ 96 IN.*				
			18 FT.	25 FT.	32 FT.	36 FT.	45 FT.
M150	15000	115"	15000	9000	5500	4000	1250
M180	18000	115"	18000	11500	7500	5750	2500
M200	20000	115"	20000	13500	9500	7500	4000
M200	20000	136"	20000	13500	9500	7500	4000
M220	22000	115"	22000	15000	10500	8500	5000
M220	22000	136"	22000	15000	10500	8500	5000
M240	24000	115"	24000	15750	11500	9500	5500
M250	25000	136"	25000	16500	12250	10000	6000
M270	27000	148"	27000	19000	13750	11750	8250
M300	30000	148"	30000	22000	16000	13750	10250
M350	35000	148"	35000	25250	17750	15250	12000
M420	42000	148"	42000	27000	19000	16500	13000
M440	44000	148"	44000	30000	20250	17500	14000
M520S	52000	148"	52000	41500	28750	23250	16750
M520	52000	174"	52000	41500	28750	23250	16750
M550	55000	174"	55000	44250	31500	25500	18500



Hoist, Inc.
4407 Railroad Ave. | East Chicago, IN 46312
www.Hoistlift.com | 708-458-2200 | Sales@hoistlift.com

WARRANTY SERVICES
812-359-1171 | Warrantyservices@hoistlift.com

AFTERMARKET PARTS
708-458-2200 | Parts@hoistlift.com



Some product features described are optional.
Please consult your dealer for specifications. Details of specifications and equipment
are based on information available at time of printing and may change without notice.